



Safe Change Housing

Type H0



Overview

The H0 Safe Change Housing is designed and tested to extract particles and aerosols from the air. Easy and safe filter exchange is provided using the double flanged Bag-In / Bag-out system, providing full protection to maintenance staff within hazardous conditions while using for radioactive and toxic systems.



SYSTEM FEATURES:

- Easy and safe filter change through Bag-in / Bag-out system
- Integrated filter with efficiencies from 98% up to 99.999 % @ 0.3µm
- Steel case with decontaminable powder coating
- Up to two filter stages
- Quality control according to ISO 9001



Finedust - HEPA / ULPA

FILT AIR Ltd.

- Fine Dust Filter
- Final Filter for Fan Filter Units
- Final Filter for Clean Rooms
- Final Filter for Channel Installation
- Highly Active Filter Surface - Low Pressure Drop
- Final Filter for Grid Systems

SYSTEM FEATURES:

- Easy and safe filter change through bag-in / bag-out system
- Integrated filter with efficiencies from 95% up to 99.999% (H14 according to EN 1822)
- Steel housing with decontaminable powder coating
- Up to two filter stages
- Quality control according to ISO 9001

Design

The H0 Safe Change Housing is made of steel sheeting or stainless steel with airtight welds finished with a decontaminable powder coating.

The rigid doors are closed airtight using a star knob clamping system. Pulling out of the HEPA filter from the housing is achieved by means of a special steel cord for an easier servicing operation.

The H0 Safe Change Housing automatically adjusts the clamping force via a cam and leaf spring, guaranteeing a uniform seal pressure between the filter and the housing frame. The clamping device can only be closed when the filter is properly in place, ensuring safe operation.

Dimensional Drawing:

(All dimensions are in mm)

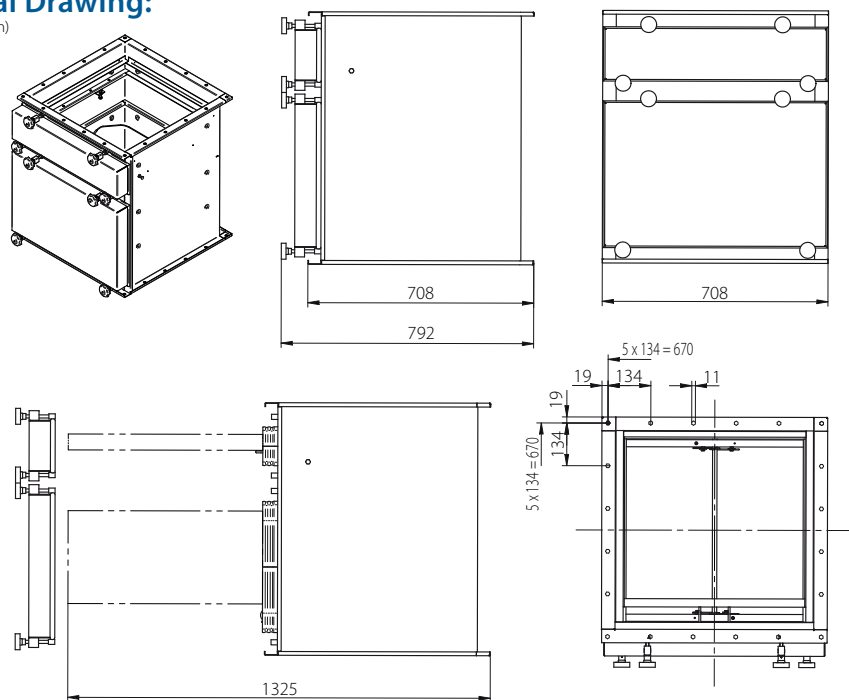

Additional Options

The H0 Safe Change Housing can be delivered with a portable table for easier replacement of the filters. Further, a 'pressure drop measuring adaptor' can be installed from the front side.

The housing flange can be supplied either with holes or with rivet nuts, according to customer requirements (see pictures).



With rivet nuts



Without rivet nuts

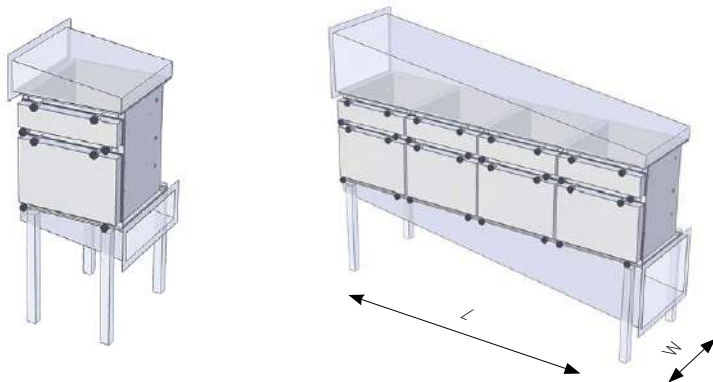

Standard Dimensions 'Single Row'

Qty. of Modules	Length	Width
1	710 mm	792 mm
2	1420 mm	792 mm
3	2130 mm	792 mm
4	2840 mm	792 mm
5	3550 mm	792 mm
6	4260 mm	792 mm

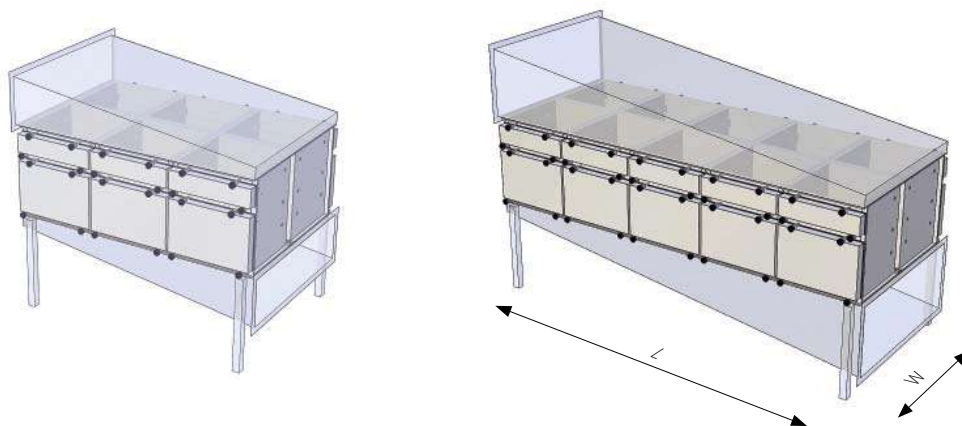

Standard Dimensions 'Double Row'

Qty. of Modules	Length	Width
1	710 mm	1584 mm
2	1420 mm	1584 mm
3	2130 mm	1584 mm
4	2840 mm	1584 mm
5	3550 mm	1584 mm
6	4260 mm	1584 mm

Finedust - HEPA / ULPA



Order Numbers

Order no.	H0	A	-	B	-	C	-	D	E	F	G
Example	H0	G	-	79	-	66	-	C	6	0	0

Filter Stage	A	Housing Frame Heights	B	Filter Dimensions	C	Housing Material	D	Housing Configuration	E	Additional Options of Housings	F	Prefilter Height	G
Two stage Filtration	G	Height 560 mm	56	610 x 610 mm	66	Steel Housing Powder Coated	C	One Filter	1	No Addition	0	No Options	0
One stage Filtration	H	Height 792 mm	79	610 x 305 mm	63	Stainless Steel	F	Two Filter	2	With Scan unit	1	Prefilter Height 4" (102 mm)	1
		Height 842 mm	84	762 x 610 mm	76	Stainless Steel Housing Powder Coated	G			Horizontal	3	Prefilter Height 2" (51 mm)	2
		Height 892 mm	89	915 x 610 mm	96					Gel Sealing Housing	4	Prefilter height 6" (153 mm)	3
Other dimensions available upon request													

Specifications are subject to change without prior notice.

HEPA & ULPA Filters for Industrial Clean Rooms

FILT AIR Ltd. specializes in the use of advanced technologies to implement a purified air supply for high-tech industry clean rooms, the microelectronics business sectors, and pharmaceutical industries. FILT AIR Ltd. has a broad range of client groups, such as hospitals, industrial plants, commercial buildings, and companies requiring clean air inside gas turbines.

FILT AIR's range of products is designed and produced in order to achieve the highest possible quality and offers safety and reliability with optimum prices and product availability. Since 2001, FILT AIR Ltd. has been registered and certified for Quality Management according to ISO 9001 (Registration No: IQNet: IL-24203).

FILT AIR Ltd.

Member of the Beth-El Group

Main Office: P.O. Box 166
Zikhron Yaaqov, 3095101, Israel
Tel: + 972-4-610 7777
Fax: + 972-4-635 0396
info@filt-air.com
www.filt-air.com