

# AIR TERMINAL INDUCTION CHILLED BEAM UNIT

BRINGING COMFORT TO INDOOR VENTILATION



# Benefits of Air Terminal Chilled Beam Unit (ATCBU)

## 1. Capacity

High BTU Capacity with Active drain connection

## 2. First Cost

Significant First Cost savings (25-35%) in comparison to VAV Systems can be realized with application of ATCB Units

## 3. Lower Operating Cost

Specially developed efficient nozzles and aerodynamic design that lowers Static Pressure requirement of ATCB vis-à-vis energy consumption of Roof Top Unit (RTU)

## 4. Lower Maintenance Cost

No Fan and Motors

No Wiring

No Moving Parts

Only periodic cleaning of Coils and Lint Screen is recommended

## 5. Additional Benefits

System qualifies for LEED accreditation

Excellent IAQ Control

Low Noise Contribution to Space

Greater Thermal Comfort

ETL Tested Unit

## Air Flow Distribution And Velocity Profile Of Linear Ceiling Induction Chilled Beam

(Model was formalized with inputted data from a live project requiring distribution pattern in a classroom environment)

CFD - CFX Tascflow

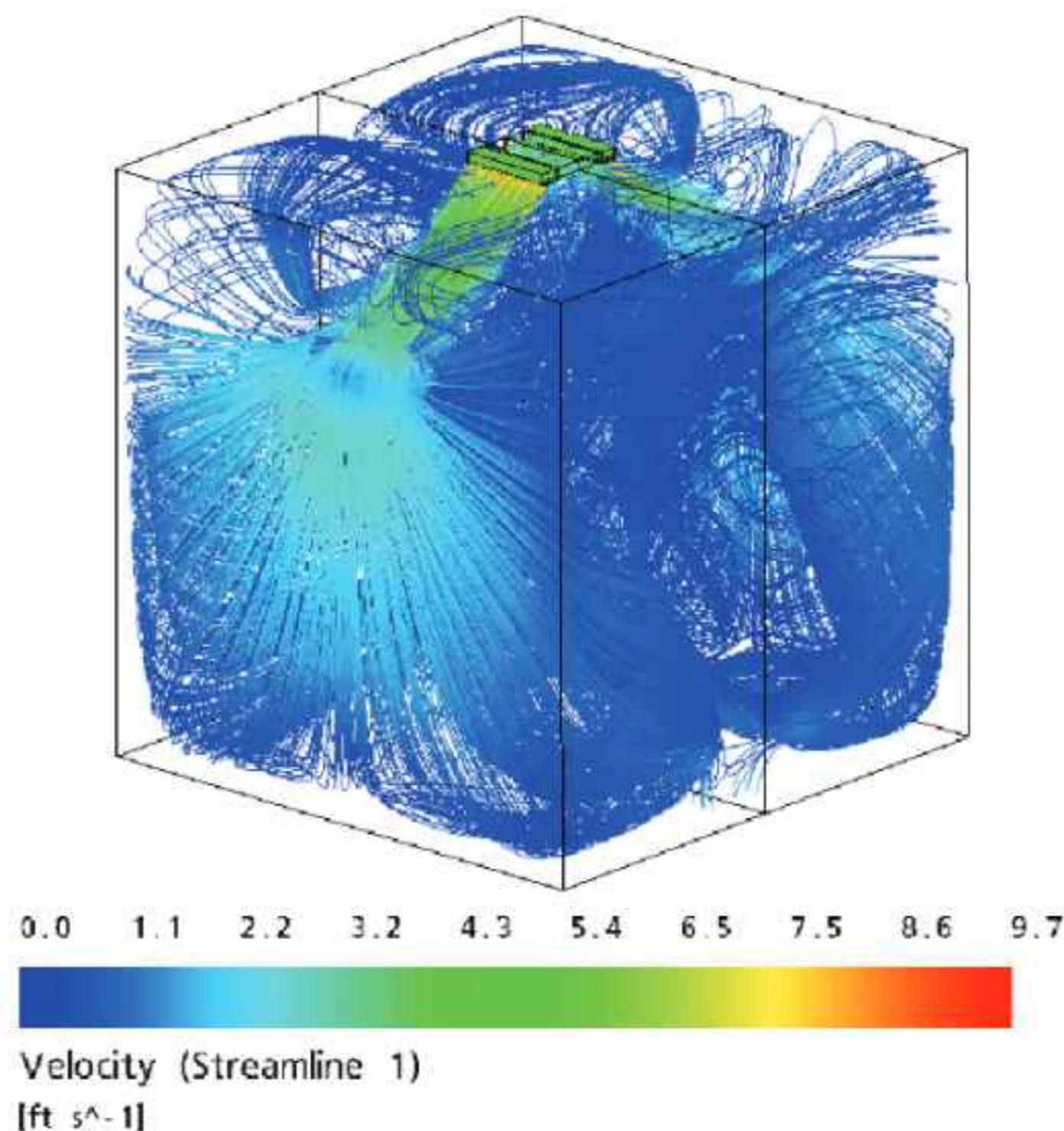

# Ceiling Mounted Vertical Down Flow Unit

## **Single Throw Unit – 1MLD 48/64/88/120 – (24 X 48) Inches**

Model Range: 4 length units to accommodate wide range of loads with 2/4 pipe systems.

The unit utilizes induction unit arrangement (ceiling 24 x 48 inches arrangement) where coil is vertically placed with air flow discharge down from the ceiling. The discharge pattern is adjustable to gain maximum footprint at a given velocity. Design consideration is given to minimize any down draft velocity that causes maximum air hitting a given spot. The unit can have variations to air and water connection. EWT to coil can be maintained as low as 45F and the unit has a full proof drain pan (per IBC) to collect any residue condensate. On account of aerodynamic discharge profile, the unit also maintains very low noise level at the same time operating at a modest pressure range.

Primary Air: 20-190 cfm

Primary Air Inlet Pressure: 0.4" - 1.5"wc

Sensible Cooling Range @ 50F EWT: 2350-6500 BTUH

Sensible Heating Range @ 180F EWT: 5450-16250 BTUH

Noise Level: NC 23-NC 33

ETL Tested Unit

Supply/Return Grille: (24 x 48) inches



## **Double Throw Unit – 2MLD 48/64/88/120 – Rectangular (24 x48) Inches**

Model Range: 2 length units to accommodate wide range of loads with 2/4 pipe systems.

The unit utilizes induction unit arrangement (ceiling 24 x 48 inches arrangement) where coil is vertically placed with air flow discharge down from the ceiling. The discharge pattern is adjustable to gain maximum footprint at a given velocity. Design consideration is given to minimize any down draft velocity that causes maximum air hitting a given spot. The unit can have variations to air and water connection. EWT to coil can be maintained as low as 45F and the unit has a full proof drain pan (per IBC) to collect any residue condensate. On account of aerodynamic discharge profile, the unit also maintains very low noise level at the same time operating at low pressure range. On account of its size the unit provides an architectural look on the ceiling corresponding to TBAR grid. The placement of these is generally at the core of the room keeping in consideration the throw/velocity of air discharge.

Primary Air: 40-400 cfm

Primary Air Inlet Pressure: 0.4" - 1.5"wc

Sensible Cooling Range @ 50F EWT: 4700-12900 BTUH

Sensible Heating Range @ 180F EWT: 10900-32500 BTUH

Noise Level: NC 25-NC 35

ETL Tested Unit

Supply/ Return Grille: (24 x 48) inches

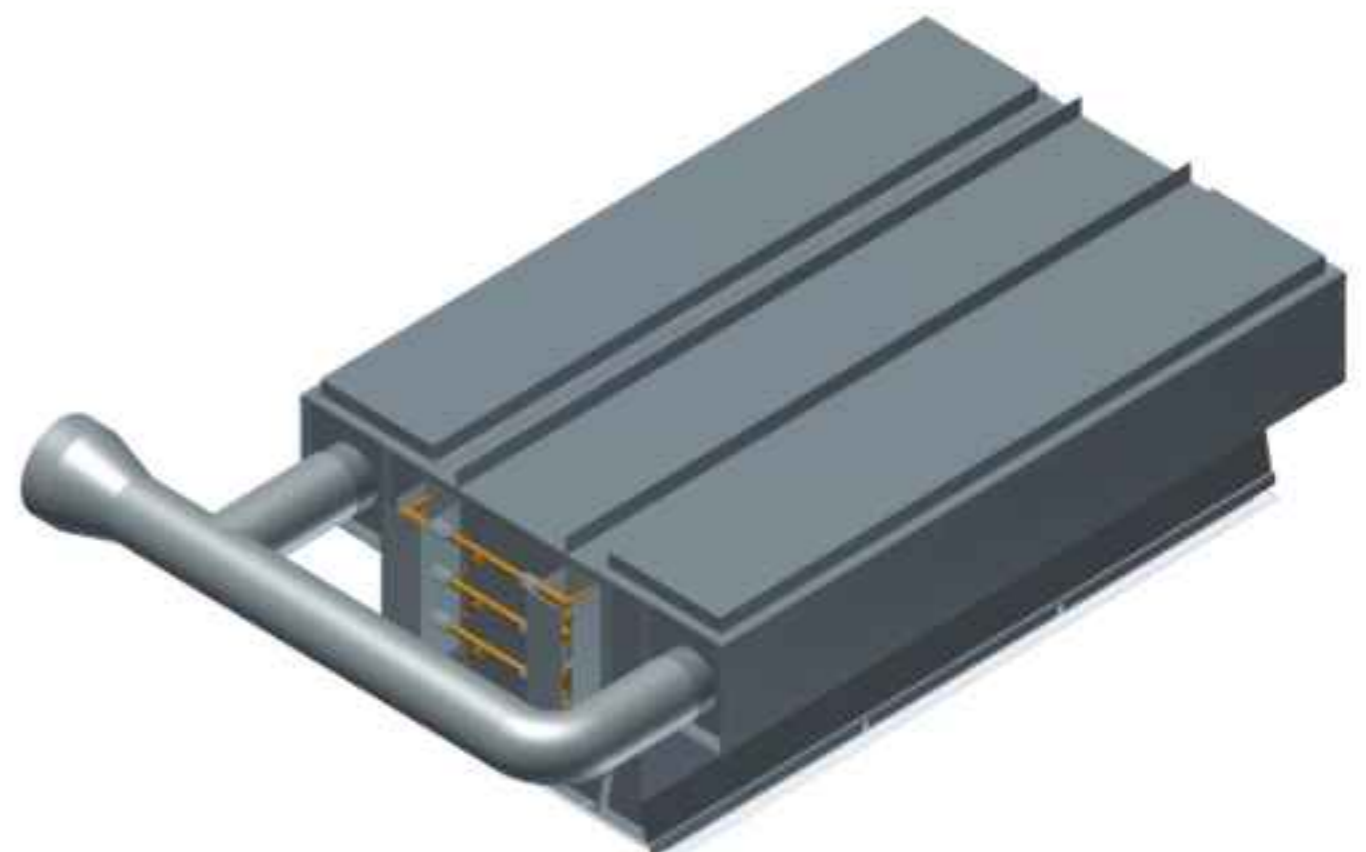
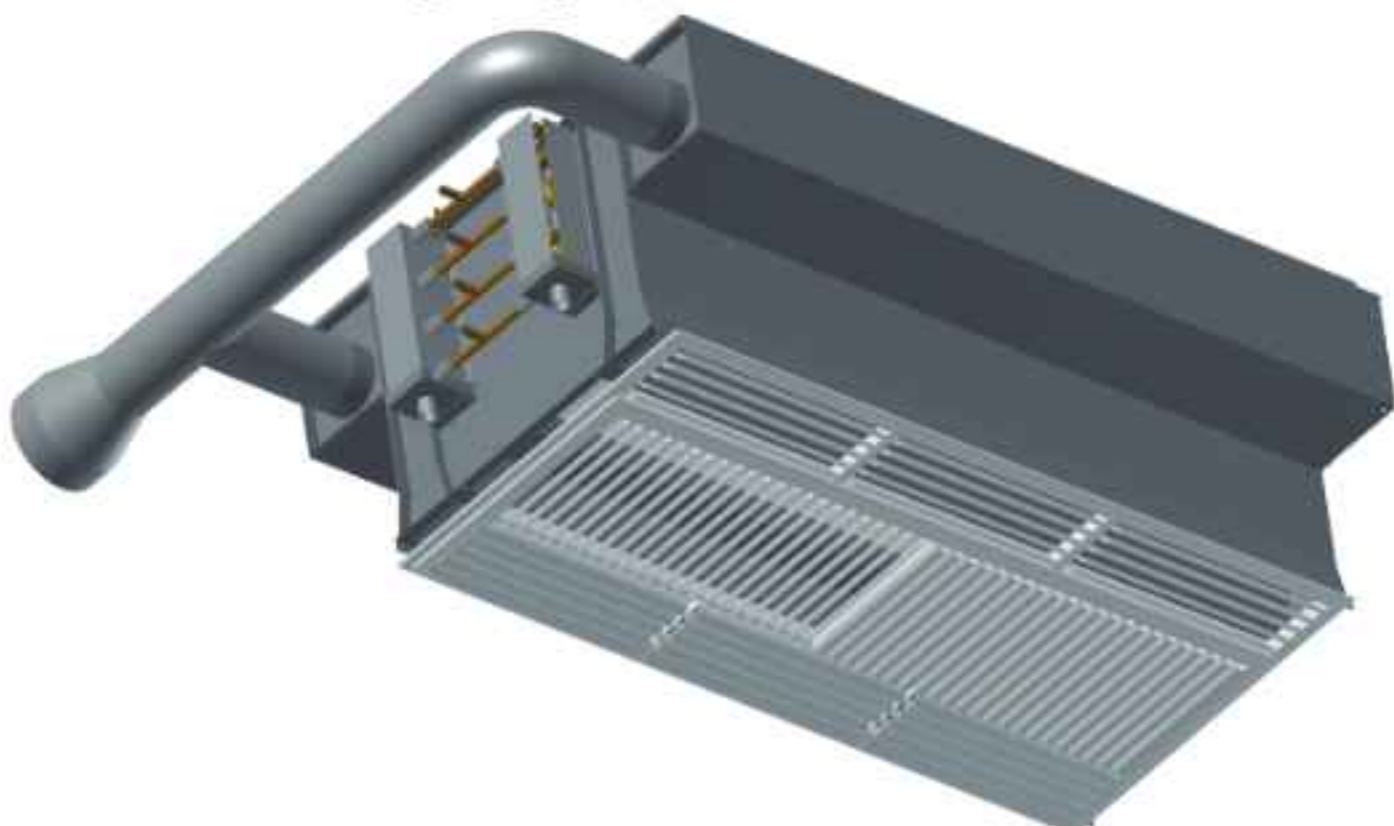

### **Single Throw Unit - 1MLD 48/64 - Square (24 X 24) Inches**

Model Range: 4 different length units to accommodate wide range of loads with 2/4 pipe systems.

The unit utilizes induction unit arrangement (ceiling 24x 24 inches arrangement) where coil is vertically placed with air flow discharge down from the ceiling. The discharge pattern is adjustable to gain maximum footprint at a given velocity. Design consideration is given to minimize any down draft velocity that causes maximum air hitting a given spot. The unit can have variations to air and water connection. EWT to coil can be maintained from 45F – 58F and the unit has a full proof drain pan (per IBC) to collect any residue condensate. On account of aerodynamic discharge profile, the unit also maintains very low noise level between NC 22-35 at the same time operating at pressure range of 0.5-1.0"WC. On account of its size the unit gives a symmetrical look on the ceiling through the T BAR. The placement of these units is along the perimeter or in the core of the room keeping in consideration of the throw of air.

Primary Air: 20-115 cfm

Primary Air Inlet Pressure: 0.4"- 1.5"wc

Sensible Cooling Range @ 50F EWT: 2200-3800 BTUH

Sensible Heating Range @ 180F EWT: 5800-10000 BTUH

Noise Level: NC 23-NC 33

ETL Tested Unit

Supply/ Return Grille: (24 x 24) inches

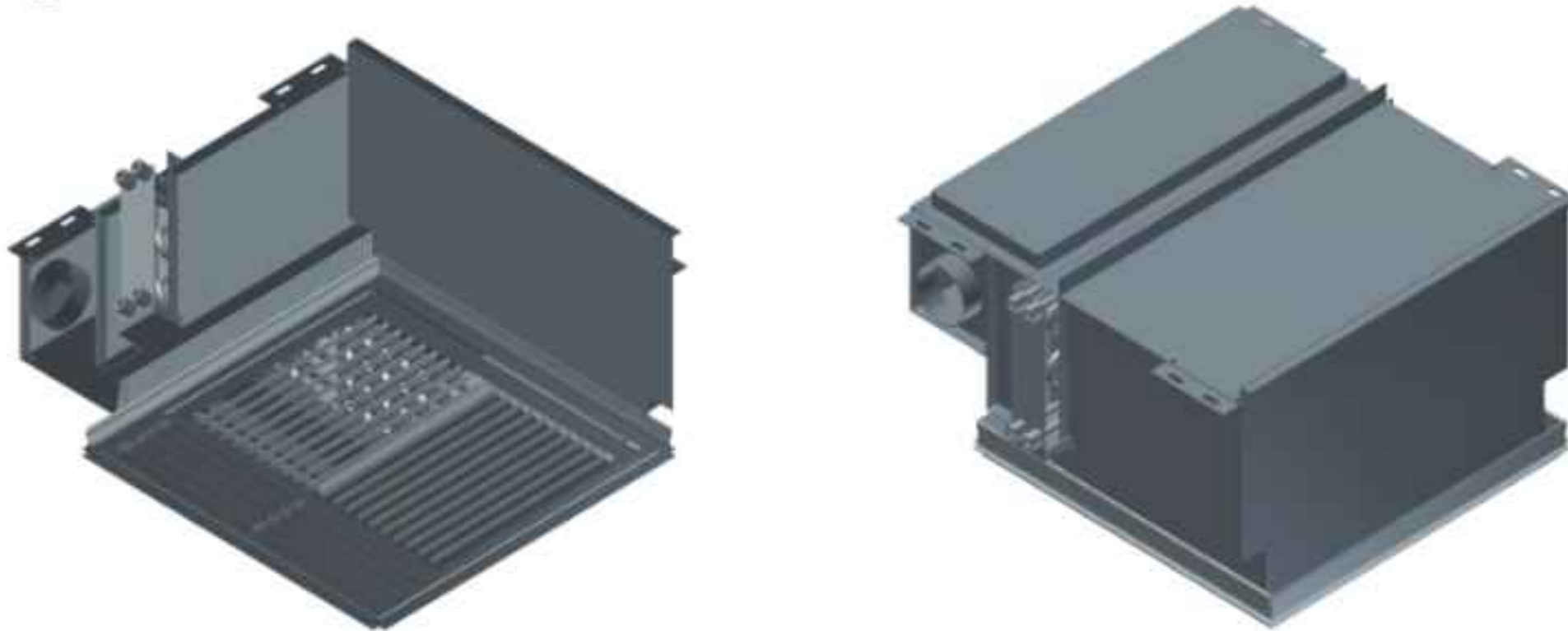

### **Double Throw Unit - 2MLD 48/64 - Square (24 x 24) Inches**

Model Range: 2 different length units to accommodate wide range of loads with 2/4 pipe systems.

The unit utilizes induction unit arrangement (ceiling 24 x 24 inches arrangement) where coil is vertically placed with air flow discharge down from the ceiling. The discharge pattern is adjustable to gain maximum footprint at a given velocity. Design consideration is given to minimize any down draft velocity that causes maximum air hitting a given spot. The unit can have variations to air and water connection. EWT to coil can be maintained as low as 45F and the unit has a full proof drain pan (per IBC) to collect any residue condensate. On account of aerodynamic discharge profile, the unit also maintains very low noise level at the same time operating at low pressure range. On account of its size the unit provides an architectural look on the ceiling corresponding to T BAR grid. The placement of these is generally at the core of the room keeping in consideration the throw/velocity of air discharge.

Primary Air: 40-230 cfm

Primary Air Inlet Pressure: 0.4"- 1.5"wc

Sensible Cooling Range @ 50F EWT: 4700-9100 BTUH

Sensible Heating Range @ 180F EWT: 10900-19600 BTUH

Noise Level: NC 25-NC 35

ETL Tested Unit

Supply/ Return Grille: (24 x 24) inches

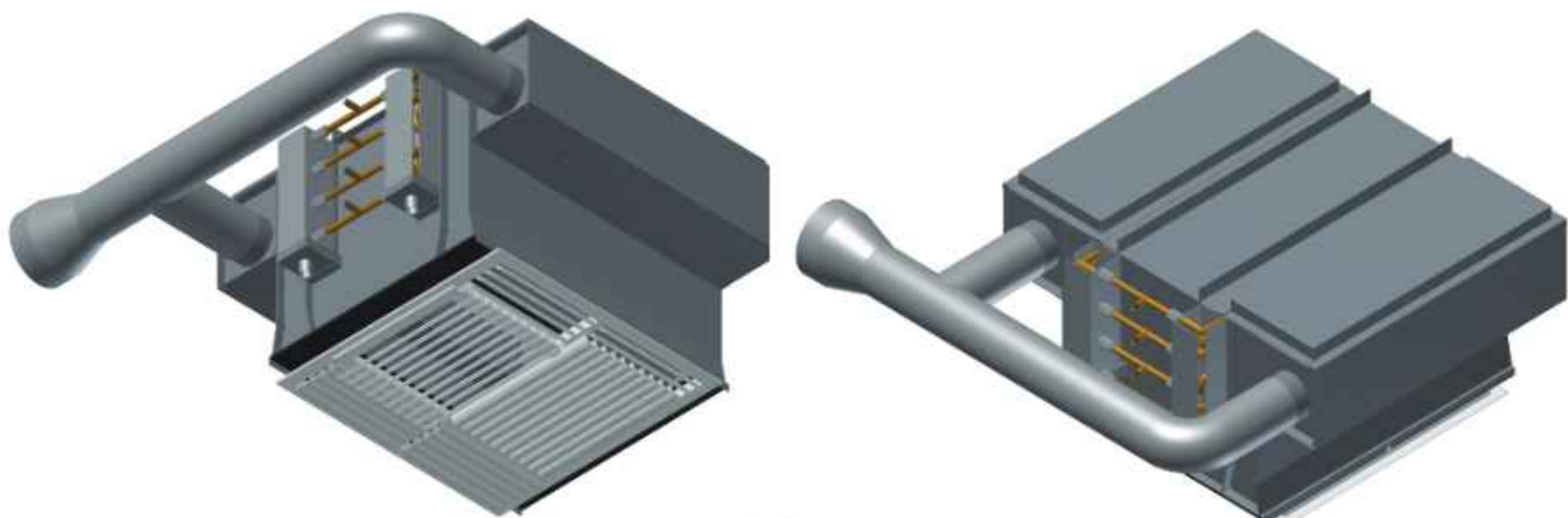

### **Single Throw Unit – 1MLD 48/64/88/120 – Slim line (12 X 48) Inches**

Model Range: Single length unit to accommodate wide range of loads and long ceiling space..

The unit utilizes induction unit arrangement (ceiling 12 x 48 inches arrangement) where coil is vertically placed with air flow discharge down from the ceiling. The discharge pattern is adjustable to gain maximum footprint at a given velocity. Design consideration is given to minimize any down draft velocity that causes maximum air hitting a given spot. The unit can have variations to air and water connection. EWT to coil can be maintained as low as 45F and the unit has a full proof drain pan (per IBC) to collect any residue condensate. On account of aerodynamic discharge profile, the unit also maintains very low noise level at the same time operating at a modest pressure range.

Primary Air: 20-190 cfm

Primary Air Inlet Pressure: 0.4" - 1.5"wc

Sensible Cooling Range @ 50F EWT: 2350-6500 BTUH

Sensible Heating Range @ 180F EWT: 5450-16250 BTUH

Noise Level: NC 23-NC 33

ETL Tested Unit

Supply/Return Grille: (12 x 48) inches

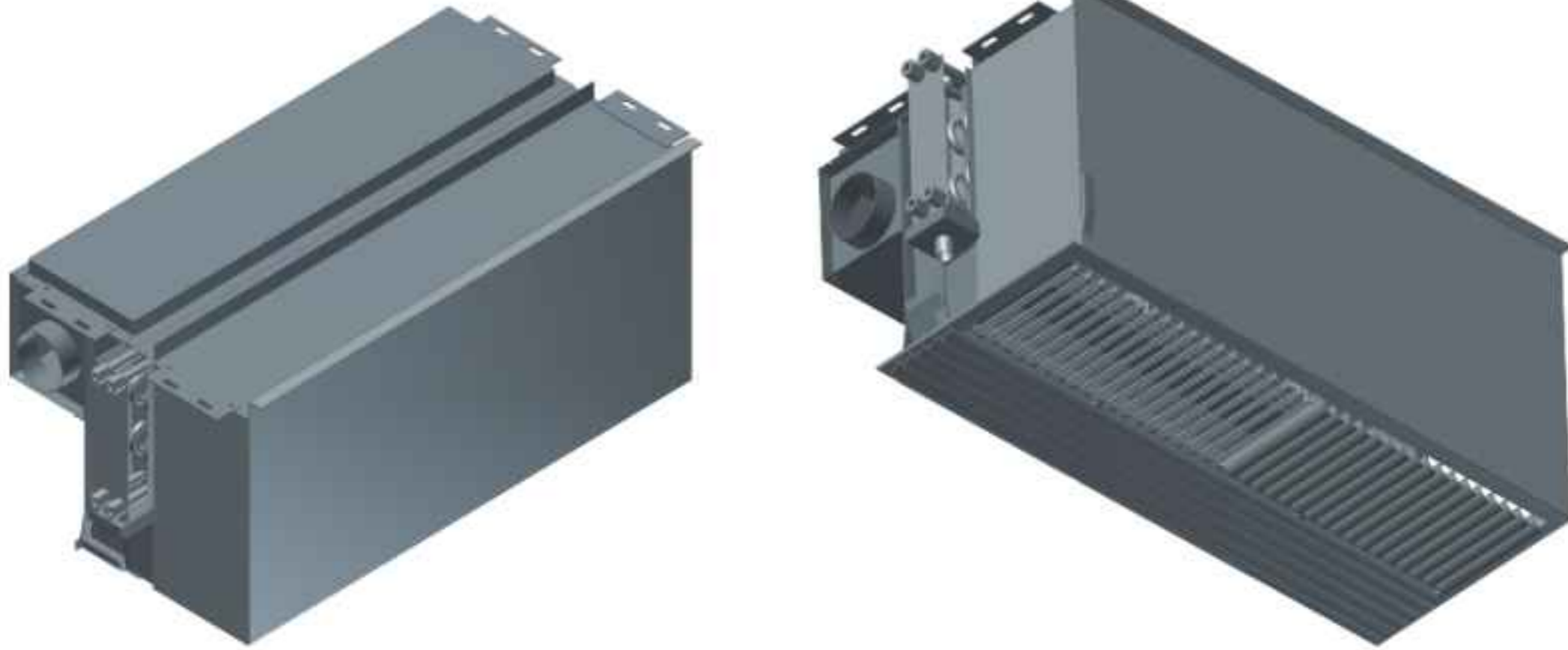

### **Double Throw Unit – 2MLD 120 – Square (48 x 48) Inches**

Model Range: Large capacity unit to accommodate wide range of loads with 4 pipe systems.

The unit utilizes induction unit arrangement (ceiling 48 x 48 inches arrangement) where coil is vertically placed with air flow discharge down from the ceiling. The discharge pattern is adjustable to gain maximum footprint at a given velocity. Design consideration is given to minimize any down draft velocity that causes maximum air hitting a given spot. The unit can have variations to air and water connection. EWT to coil can be maintained as low as 45F and the unit has a full proof drain pan (per IBC) to collect any residue condensate. On account of aerodynamic discharge profile, the unit also maintains very low noise level at the same time operating at low pressure range. On account of its size the unit provides an architectural look on the ceiling corresponding to TBAR grid. The placement of these is generally at the core of the room keeping in consideration the throw/velocity of air discharge.

Primary Air: 40-230 cfm

Primary Air Inlet Pressure: 0.4" - 1.5"wc

Sensible Cooling Range @ 50F EWT: 4700-12900 BTUH

Sensible Heating Range @ 180F EWT: 10900-32500 BTUH

Noise Level: NC 25-NC 35

ETL Tested Unit

Supply/ Return Grille: (48 x 48) inches

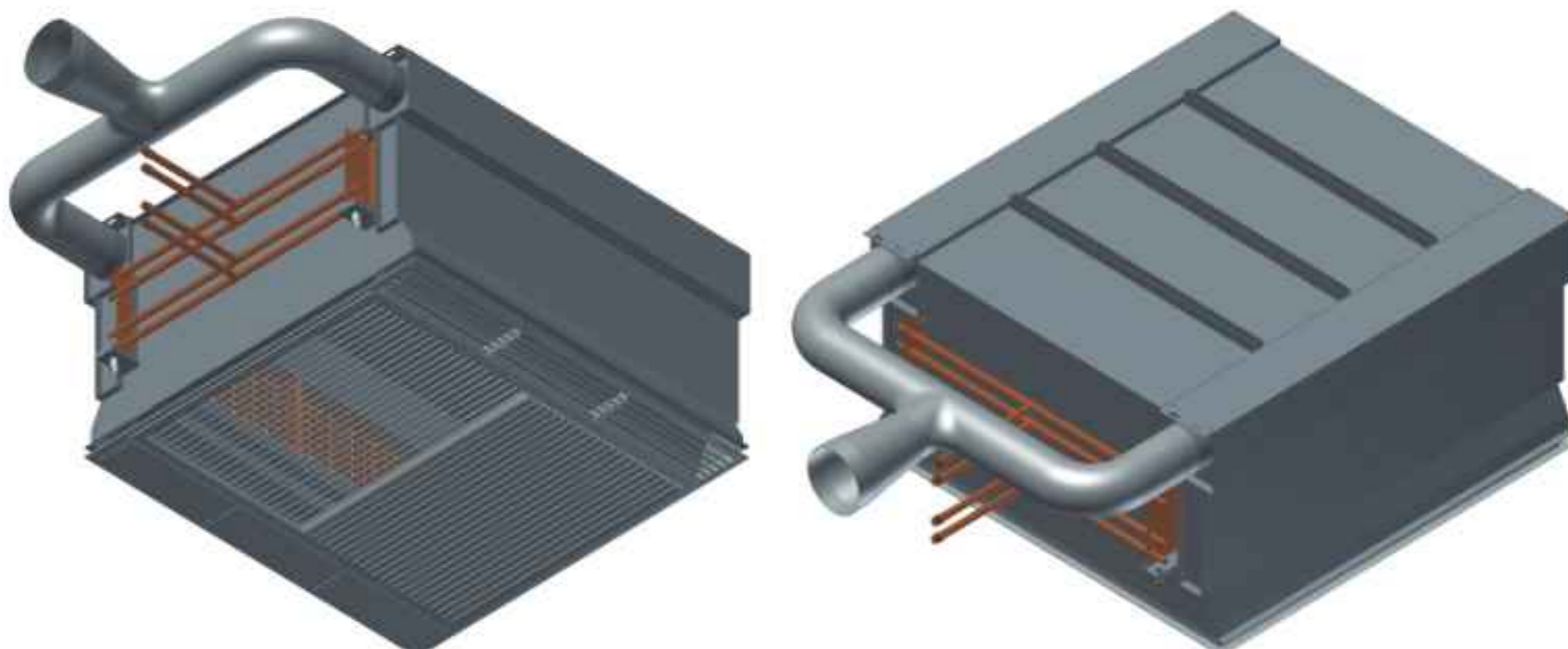

## **Single Throw Unit – 1MLD 48/64/88/120 – Slim line (12 X 48) Inches**

Model Range: 4 different length units to accommodate wide range of loads with 2/4 pipe system.

EB Air Bulkhead unit utilizes Induction principle by a different arrangement to which air is discharged out of the unit parallel to the ceiling. The aerodynamic nozzles eject air at a high velocity which accentuates a greater throw of 10-24 ft of the discharge grille at 100fpm velocity. The design characterizes better throw and capacity thus keeping the unit quiet in its operation. Rated noise level is within NC-20-32 varying with operating attributes.

Soffit Induction model has variety of applications from school classrooms, hotels to conference rooms where flow, temperature as well throw is crucial driver to space conditioning and comfort cooling.

The unit can be customized to fit any size or opening along with alternating air water connection. Grilles colour can also be customized according to architect's requirement.

Primary Air: 20- 190 cfm

Primary Air Inlet Pressure: 0.4"- 1.5" wc

Sensible Cooling Range @ 50F EWT: 2350- 6500 BTUH

Sensible Heating Range @180F EWT: 5450- 16,250 BTUH

Noise Level: NC 23-33

ETL Tested Unit

Built in drain pan complying to IBC code (condensate collect for low EWT)

Return Grille: (12 x 24) or (12 x 48) inches

Supply Grille: (4 x 24) or (4 x 48) inches

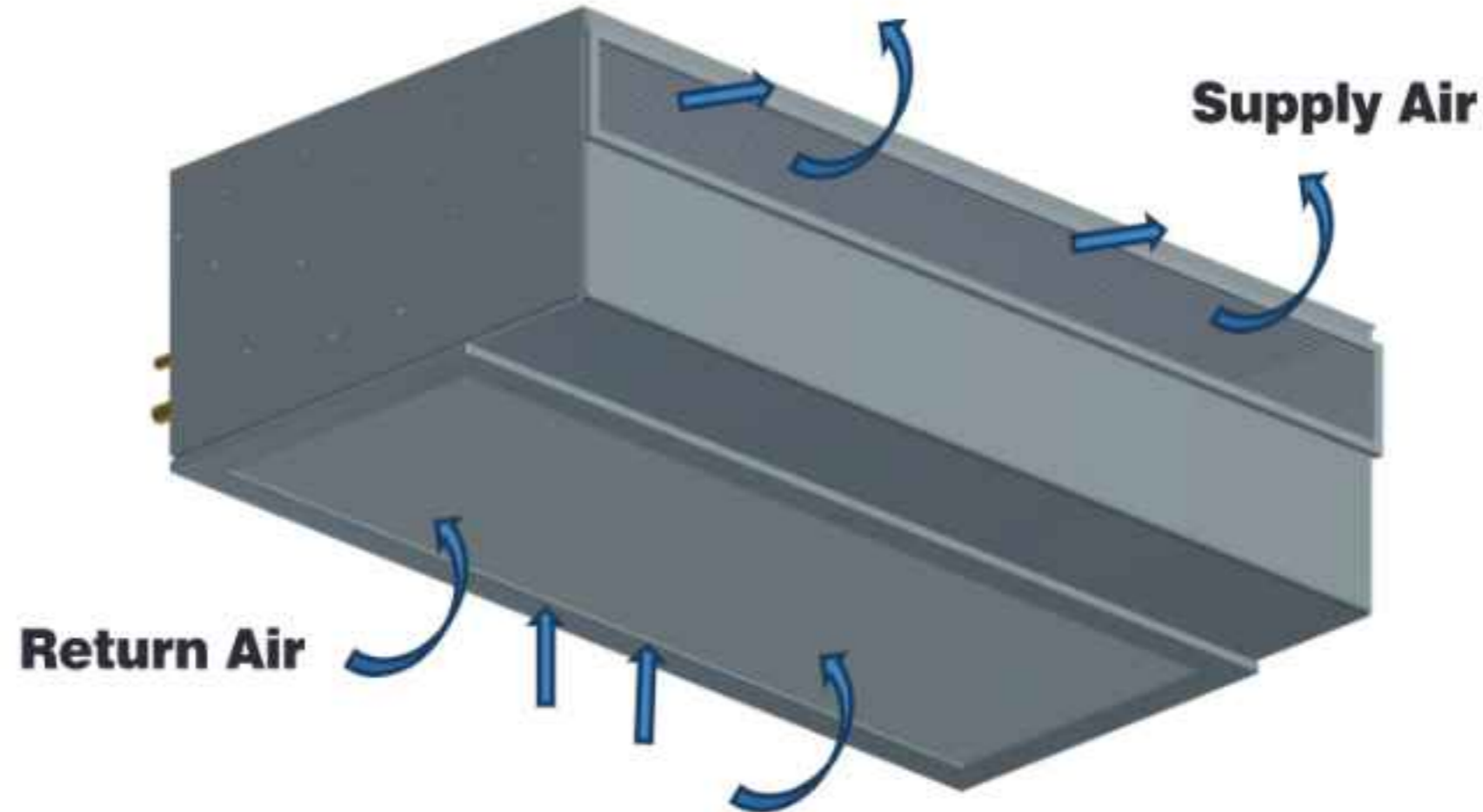

## Cost Effective Way to Provide Healthy Air

ATCBU is a ceiling mounted high capacity air supply terminal with no moving parts. Ventilation air, conditioned in a central air apparatus is filtered, dehumidified and cooled or heated, ducted to the ATCBU units. Treated Primary air from the ATCBU is released through special nozzles, inducing room air through a cooling coil which offsets sensible heat from occupants, lights, equipments outside sun transmitted to the space. The mixture of ventilation air with the conditioned room air is jetted down to provide high level of invigorating air movement at the occupant's breathing level.

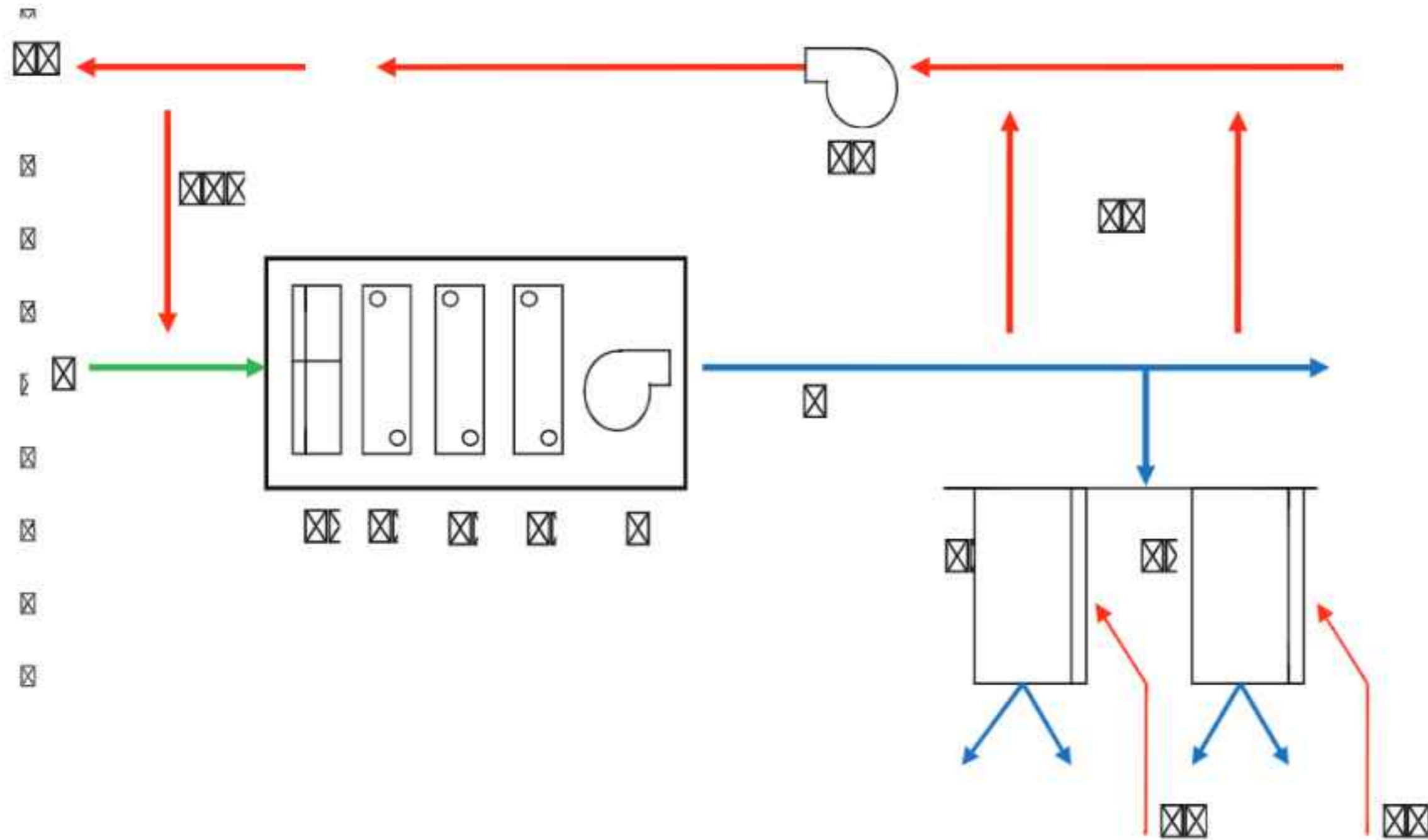

1. Outside air intake
2. High Efficiency Filter
3. Preheat Exchanger
4. Cooling & Dehumidification Coil removes some of Latent Heat from outside air and occupied zone
5. Reheat Coil : Temperature Scheduled by outside temperature
6. Supply Air Fan : Supplies Primary / Ventilation Air
7. Medium Pressure Duct
8. ATCB air supply units : Discharges Medium pressure Primary air through Nozzles creating Jet flow effect which induces room air through terminal unit coils. Mixed air stream is supplied through directional ceiling diffusers to occupied zone
9. Room Return
10. Relief air from occupied zone to ceiling plenum above corridor
11. Relief/central return fan
12. Optional return air : Unoccupied or Partially occupied periods
13. Relief air to outside

# AIR TERMINAL INDUCTION CHILLED BEAM UNIT

BRINGING COMFORT TO INDOOR VENTILATION

## Merits of Ceiling Air Terminal Induction Chilled Beam

- ✔ Low Noise (Quiet Operation)
- ✔ No Clogging of Nozzles- Minimal Maintenance
- ✔ No Liners or Erosive Materials for Potential Health Hazards
- ✔ Washable Screens, No Replacements
- ✔ High Capacity, Low Energy Consumption (No Electrical Fan or Motor)
- ✔ Qualify As Energy Saving Product- Leed Building
- ✔ Built With Drain Pan, Hence No Issue With Condensation.
- ✔ Air And Water Side Controls Optional
- ✔ Built-in Redundancy- Eliminates Multiple Active Ceiling Chilled Beams



Efficient, Low-Maintenance  
Climate Control with  
Air-Terminal Induction  
Chilled Beam Technology

**EB AIR CONTROL INC.**  
MANUFACTURERS OF INNOVATIVE HVAC PRODUCTS

6185, Tomken Road, Unit 1-2,  
Mississauga, ON, L5T 1X6, Canada.

Ph. 905-670-2277  
Fax. 905-670-2299

[www.ebaircontrol.com](http://www.ebaircontrol.com)

